

# Vernier Height Gage

## SERIES 506 — Light-Weight Height Gage

### FEATURES

- The Light-Weight Height Gage is designed for scribing from a vertical base or for small parts.
- Satin chrome-finished scales for glare-free reading.
- Beam and slider are made of stainless steel.
- Carbide-tipped scriber is provided.



### SPECIFICATIONS

#### Metric

Range	Order No.	Accuracy	Graduation	Mass (kg)
0 - 200mm	506-207	±0.03mm	0.02mm	1.4

#### Inch/Metric

Inch model with inch/metric double scale

Range	Order No.	Accuracy	Graduation	Mass (kg)
0 - 8" / 0 - 200mm	506-208	±.001"	.001" / 0.02mm	1.4

### DIMENSIONS

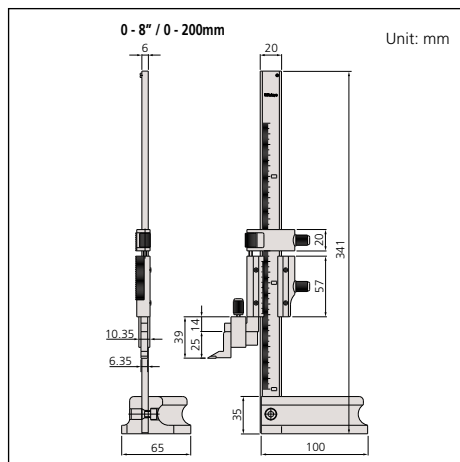

### Standard Scriber Provided

Carbide-tipped scriber (900173) and scriber clamp (901338)

### Dimension of scriber

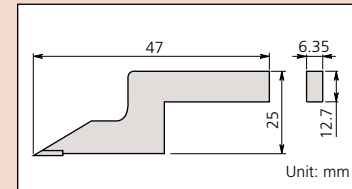

### Optional Accessories

- 953639: Holding bar for test indicator (length: 2" / 50mm)
- 900322: Swivel clamp used with holding bar

