

Vernier Depth Gage

SERIES 527

FEATURES

- Made of hardened stainless steel.
- Base and measuring faces are hardened and micro-lapped.
- Optional wider extension base are available. (up to 450mm range models)

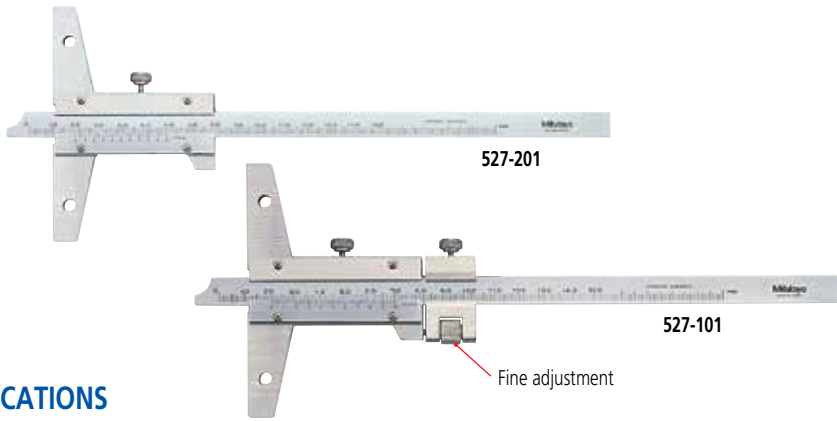

SPECIFICATIONS

Metric

Range	Order No.	Vernier reading	Accuracy	Mass (g)	Remarks
0 - 150mm	527-201	0.05mm	±0.05mm	240	—
0 - 150mm	527-121	0.02mm	±0.03mm	215	—
0 - 150mm	527-101	0.02mm	±0.03mm	280	with fine adjustment
0 - 200mm	527-202	0.05mm	±0.05mm	260	—
0 - 200mm	527-122	0.02mm	±0.03mm	230	—
0 - 200mm	527-102	0.02mm	±0.03mm	300	with fine adjustment
0 - 300mm	527-203	0.05mm	±0.08mm	300	—
0 - 300mm	527-123	0.02mm	±0.04mm	265	—
0 - 300mm	527-103	0.02mm	±0.04mm	350	with fine adjustment
0 - 600mm	527-204	0.05mm	±0.10mm	1511	—
0 - 600mm	527-104	0.02mm	±0.05mm	1511	with fine adjustment
0 - 1000mm	527-205	0.05mm	±0.15mm	1880	—
0 - 1000mm	527-105	0.02mm	±0.07mm	1880	with fine adjustment

Inch

Range	Order No.	Vernier reading	Accuracy	Mass (g)	Remarks
0 - 6"	527-111	.001"	±.001"	280	with fine adjustment
0 - 8"	527-112	.001"	±.001"	300	with fine adjustment
0 - 12"	527-113	.001"	±.0015"	350	with fine adjustment
0 - 24"	527-114	.001"	±.002"	1511	with fine adjustment
0 - 40"	527-115	.001"	±.003"	1880	with fine adjustment

DIMENSIONS

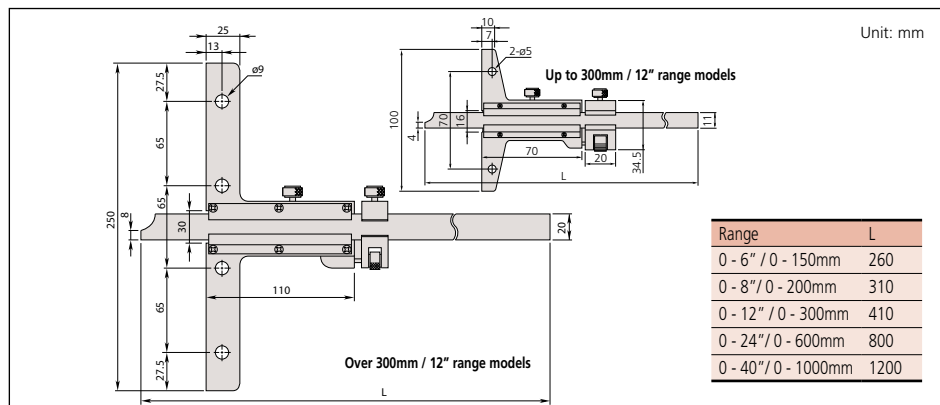

Technical Data

Graduation: .001" or 0.05mm, 0.02mm

Optional Accessories

—: Extension base (see page D-56.)