

# ABSOLUTE Digimatic Indicator ID-F

SERIES 543 — With Back-lit LCD



## FEATURES

- With ABSOLUTE linear encoder technology, once the measurement reference point has been set it, will not be lost when the power is turned on.
- Go/no-go judgment is performed by setting the upper and lower tolerances. If a judgment result is out of tolerance, the display backlighting changes from green to red, so tolerance judgment can be made at a glance.
- The maximum, minimum, or runout value can be displayed during measurement.
- An analog bar indicator has been integrated to handle upper/lower limit approaching and zero approaching. The display range can be changed.
- With SPC data output.



## SPECIFICATIONS

**Inch/Metric** Stem dia. 3/8" #4-48 UNF Thread

Resolution	Range	Order No.	Model	Accuracy
.00005", .0001", .0005", .001", 0.001mm, 0.01mm	1" / 25.4mm	<b>543-552A</b>	ID-F125E	.00012"
	2" / 50.8mm	<b>543-558A</b>	ID-F150HE	.00012"

**Metric** Stem ø 8mm M2.5 X 0.45 Thread

Resolution	Range	Order No.	Model	Accuracy
0.001mm, 0.01mm	25mm	<b>543-551A</b>	ID-F125	0.003mm
	50mm	<b>543-557A</b>	ID-F150H	0.003mm

## DIMENSIONS

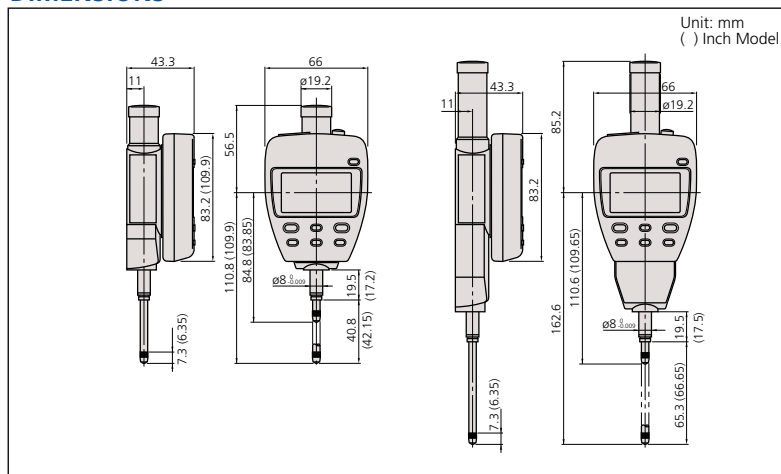

## Technical Data

Accuracy: Refer to the list of specifications  
 Resolution: 0.01mm/0.001mm or .00005"/.0001"/.0005"/.001"/.001mm/0.01mm  
 Display: LCD  
 Length standard: ABSOLUTE electrostatic capacitance type linear encoder  
 Max. response speed: Unlimited  
 Measuring force: 1.8N/2.3N\* or less (\*50mm range models)  
 Power supply: 9V DC (via AC adaptor)

## Function

Origin-set/Preset, Zeroset, Go/no-go judgment, Max/Min value hold, Runout measurement, Resolution switching, Counting direction switching, Power ON/OFF, Data output, inch/mm conversion (on inch/metric models only)  
 Alarm: Low voltage, Counting value composition error, Overflow error, Tolerance limit setting error

## Standard Accessories

**06AEG302JA**: AC Adapter 120v  
**137693**: Lifting Level

## Optional Accessories

**936937**: SPC cable (40" / 1m)  
**965014**: SPC cable (80" / 2m)  
**540774**: Spindle lifting cable (stroke: .4" / 10mm)  
**02ACA571**: Auxiliary spindle spring for 25mm/1" models\*  
**02ACA773**: Auxiliary spindle spring for 50mm/2" models\*  
**264-504-5A**: Digimatic Min-processor DP-1VR  
**543-004-1**: Digimatic presetter  
 ———: Backs (See page F-33.)  
 ———: (See page F-34.)

\*Required when orienting the indicator upside down.

## Application

### Difference/Runout measurement

**Example: Indicator travel from points A to D**

Difference (or Total Runout) is displayed as A. Dimensions B (maximum value) and C (minimum value) can be recalled from memory with a simple key sequence.

