



Dial Indicators

SERIES 2 — ANSI / AGD Type Metric Dial Indicator

SPECIFICATIONS

Graduation	Range	Range / Rev	Dial reading	Order No.		Accuracy		Measuring force	 
				w/ lug	Flat-back	First 2.5 Rev	Overall		
0.001mm	1mm	0.2mm	0-100-0	2109S-11	2109SB-11	±0.003mm	±0.004mm	1.5N or less	✓ ✓
0.001mm	5mm	0.2mm	0-100-0	2119S-11	2119SB-11	±0.007mm	±0.01mm	1.5N or less	✓
0.01mm	2.5mm	1mm	0-100	2230S-01	2230SB-01	±0.01mm	±0.01mm	1.4N or less	
0.01mm	2.5mm	1mm	0-50-0	2231S-01	2231SB-01	±0.01mm	±0.01mm	1.4N or less	
0.01mm	10mm	1mm	0-100	2046S-01	2046SB-01	±0.01mm	±0.013mm	1.4N or less	
0.01mm	10mm	1mm	0-100	2046S-11	2046SB-11	±0.01mm	±0.013mm	1.4N or less	✓
0.01mm	10mm	1mm	0-50-0	2047S-01	2047SB-01	±0.01mm	±0.013mm	1.4N or less	
0.01mm	10mm	1mm	0-50-0	2047S-11	2047SB-11	±0.01mm	±0.013mm	1.4N or less	✓
0.01mm	10mm	1mm	100-0	2902S-01	2902SB-01	±0.01mm	±0.013mm	1.4N or less	
0.01mm	20mm	1mm	0-100	2050S-01	2050SB-01	±0.01mm	±0.02mm	2.0N or less	
0.01mm	20mm	1mm	0-100	2050S-11	2050SB-11	±0.01mm	±0.02mm	2.0N or less	✓
0.01mm	25mm	1mm	0-100	2056S-01	2056SB-01	±0.01mm	±0.025mm	2.5N or less	

DIMENSIONS

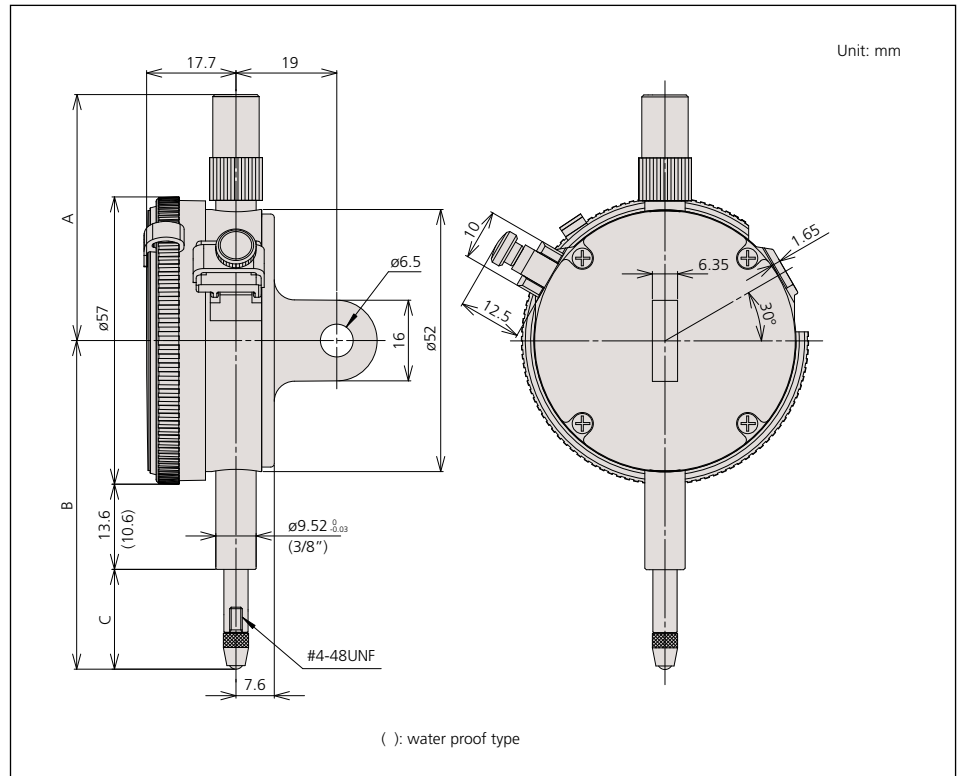

Order No.	A	B	C
2109S-11	48.8	51.4	9.3
2119S-11	48.8	55.8	13.7
2230S-01	48.8	53.6	11.5
2231S-01	48.8	53.6	11.5
2046S-01	48.8	61.1	19.0
2046S-11	48.8	61.1	19.0
2047S-01	48.8	61.1	19.0
2902S-01	48.8	61.1	19.0
2050S-01	38.8	71.1	29.0
2050S-11	38.8	71.1	29.0
2056S-01	38.8	76.1	34.0

Optional Accessories

- : Backs (See page F-33.)
- : Contact points (See page F-34.)