

MarTest 800 S / 800 S-R / 800 SG / 800 SG-R / 800 SR / 800 SA / 800 SGA



Test Indicator

FEATURES

- Standard model
- High-contrast dial face, sealed with O-ring
- Mineral glass viewing panel for best protection:
 - against cracking, scratching or damage caused by hot shavings
 - optimum resistance to solvents
- Matt chrome-plated protective casing with three integrated dovetail guide rails
- Shockproof measuring mechanism
- Anti-magnetic model
- Automatic adjustment to the contacting direction ensuring infallible readings
- Ball bearing mounted double lever
- Friction clutch overload protection
- Package contains: case, instruction manual, spanner for changing the styli, stylus dia. \varnothing 2 mm, mounting shaft 800a8



Application:

- Measurement of concentricity, alignment, parallelism and flatness
- Centering of bores and shafts
- Parallel or perpendicular alignment of work pieces

TECHNICAL DATA

Order no.	4305200 4305205 4307200 4307205 4307250 4301200 4301250						
Product type	800 S		800 S-R		800 SG		800 SGA
Measuring range	mm		± 0.4		± 0.8		± 0.25
Graduation value	mm		0.01				
Measuring surface	carbide		ruby		carbide		ruby
Scale diameter	mm		28		38		28 38
Type of dial face			40-0-40				25-0-25
Dial color					Yellow		
Measuring force	N		0.15				0.1
Range per rev.	mm		0.8				0.5
Deviation range f_e	μm		10				5
Total deviation range f_{ges}	μm		13		14		8
Hysteresis f_u	μm		3		4		3
Partial measuring span f_t	μm				5		
Repeatability f_w	μm				3		
Standard			DIN 2270				Factory standard

Order no.	a	b	c	d	e	f	Measuring anvil length
	mm	mm	mm	mm	mm	mm	mm
4305200		30	13.6	17.8	75	99	14.5
4305205		30	13.6	17.8	75	99	14.5
4307200	40.5		13.6	17.8	75	99	14.5
4307205	40.5		13.6	17.8	75	99	14.5
4307250	40.5		13.6	17.8	75	99	14.5
4301200		30	13.6	17.8	75	99	14.5
4301250	40.5		13.6	17.8	75	99	14.5

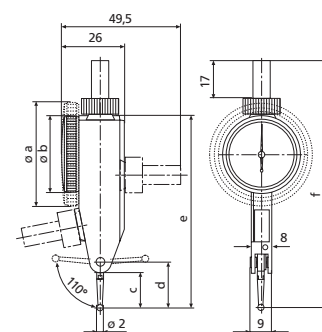

ACCESSORIES

Order no.	Product name	Product type
4305870	Stylus \varnothing 1.0 mm, carbide, l = 14.5 mm	800 ts
4305850	Stylus \varnothing 2.0 mm, carbide, l = 14.5 mm	800 ts
4305871	Stylus \varnothing 3.0 mm, carbide, l = 14.5 mm	800 ts
4309051	Stylus \varnothing 2.0 mm, ruby, l = 14.5 mm	800 tsr
4305868	Spanner	

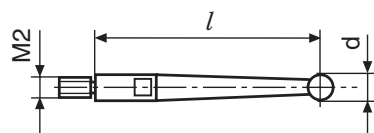

800 tb;800 tbr;800 te;800 ter;800 tl;800 tlr;800 ts;800 tsr;801 tl