

# MarCator 1075 R

## Digital Indicator



### FUNCTIONS

- ON/OFF
- RESET (set display to zero)
- mm/inch
- Reversal of counting direction
- PRESET (for entering a numerical value)
- DATA (data transmission via connection cable)
- LOCK function (key lock)
- AUTO-ON / OFF



### FEATURES

- High contrast LCD
- Hermetically sealed protective measuring spindle cap
- Mounting shank and measuring spindle are both made of hardened stainless steel
- **Digit height:** 12 mm
- **Data interface:** Digimatic, Opto RS232C, USB
- **Energy supply:** Battery life approx. 3 years
- **IP protection category:** IP 52
- **Package contains:** battery, instruction manual

### Application:

Simple measuring function for **static measurements** such as lengths, distances and length differences

### TECHNICAL DATA

Order no.	4336010	4336020	4336030
Product type		1075 R	
Measuring span	mm	12.5	
Measuring span	inch	.5"	
Resolution	mm	0.01	0.001
Resolution	inch	.0005"	.00005"
Error limit	mm	0.02	0.015
Measuring force	N	0.5 – 1	
Standard		Factory standard	
Protective measuring spindle cap		•	

Order no.	Mounting shaft
4336010	8
4336020	8
4336030	8

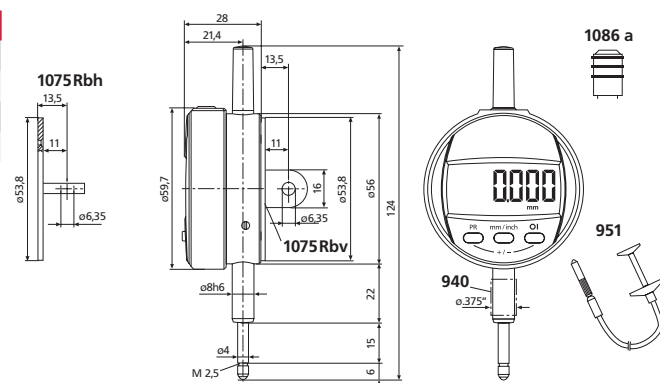

### ACCESSORIES

Order no.	Product name	Product type
4102357	16 EXu Data connection cable USB (2 m)	16 EXu
4102915	Digimatic data cable (2 m)	16 EWd
4102410	Data connection cable RS232C (2 m)	16 EXr
4310103	Adapter bush (.375" / 8 mm)	940
4372000	Cable release (250 mm)	951
4375004	Protective cap for 1075 R / 1086 R / 1087 R	1086 s
4337320	Lift-off cap, complete 12.5 / 25 mm	
4336041	Lug back, horizontal	1075 Rbh
4336042	Lug back, vertical	1075 Rbv
4102520	Battery 3 V, CR 2032	